

PHILIPS

TrustSight

Emergency kit



TrustSight Gen 3+

LED Emergency Lighting Kit

TrustSight Emergency drivers

The application of LED technology within the lighting sector also requires integration of reliable emergency lighting equipment inside luminaires. The range of TrustSight emergency lighting solutions offers easy design-in and is compatible with all dimmable and non-dimmable linear high voltage and SELV LED drivers. The TrustSight emergency driver is designed for maintained solutions but can also be used in a non-maintained emergency lighting configuration. It offers self-testing (IEC 62034) and is available with min. 3 hours emergency duration for all driver-battery pack combinations. Two battery technologies are supported by TrustSight: NiMH batteries and lithium-ion batteries. The TrustSight LED emergency drivers come with battery harness. The TrustSight driver can also be used as an independent emergency driver with the separately available strain relief accessories.

Benefits

- Compliant with prevalent international standards
- Easy system integration with LED driver and LED modules
- Built-in and Independent use
- Supports Insulation Class I and II applications

Features

- Constant output power
- Compatible with NiMH and Li-Ion batteries
- Automatic cell count detection
- Double-insulated/SELV or HV output
- LFP temperature sensing
- Double-insulated DALI
- DALI-2 certified

Applications

- Offices, supermarkets, department stores, schools, etc.

October 2023

Logistical data

Product name	12NC	Pieces per box
TrustSight Basic 15-55V NiMH+	9290 034 18606	10
TrustSight Basic 45-300V NiMH+	9290 034 18506	10
TrustSight PRO 15-55V NiMH+	9290 034 18406	10
TrustSight PRO 45-300V NiMH+	9290 034 18906	10
TrustSight DALI 15-55V NiMH+	9290 034 18806	10
TrustSight DALI 45-300V NiMH+	9290 034 18706	10
TrustSight Basic 15-55V LFP+	9290 034 18306	10
TrustSight Basic 45-300V LFP+	9290 034 18206	10
TrustSight PRO 15-55V LFP+	9290 034 18106	10
TrustSight PRO 45-300V LFP+	9290 034 18006	10
TrustSight DALI 15-55V LFP+	9290 034 17906	10
TrustSight DALI 45-300V LFP+	9290 034 17806	10

The TrustSight PRO and DALI types are equipped with self-test functionality according to IEC 62034. The TrustSight Basic can only be tested manually (via mains interruption or with a test switch). Battery connection cable harness is included in the driver box. The LED indicator must be ordered separately.

Product name	12NC	Weight [Gram]	Pieces per box
TrustSight 3.6V 3cell 4000mAh battery NiMH	9290 016 52506	200	10
TrustSight 4.8V 4cell 4000mAh battery NiMH	9290 016 52606	270	10
TrustSight 6.0V 5cell 4000mAh battery NiMH	9290 016 52706	340	10
TrustSight 3.2V 3cell 4500mAh battery LFP+	9290 034 19206	148	10
TrustSight 6.4V 4cell 3000mAh battery LFP+	9290 034 19106	200	10
TrustSight 9.6V 6cell 3000mAh battery LFP+	9290 034 19006	295	10
TrustSight 6.4V 4cell 3000mAh LFP+ FRC	9290 034 23206	205	10

The selected TrustSight battery pack will determine the output power in emergency mode.

Product name	12NC	Pieces per box
TrustSight Strain relief	9290 016 53306	20
TrustSight battery independent box	9290 016 53406	10
TrustSight LED indicator	9290 016 53606	20
TrustSight battery harness NiMH	9290 016 82206	20
TrustSight battery harness LFP+	9290 034 19406	20
TrustSight battery harness LFP+ FRC	9290 034 23506	20
TrustSight High Brightness LED indicator	9290 021 70606	100

EM system contains:

TrustSight driver for built-in application



TrustSight driver for independent application



Wiring & Connections

Electrical input data

Specification item	Value	Unit	Condition
Rated input voltage range	220 ... 240	Vac	
Rated input frequency range	50 ... 60	Hz	
Rated input current	30	mA	@230Vac, 2S3P LFP pack
Rated input voltage	230	Vac	
Rated input power	6	W	@230Vac, 2S3P LFP pack
Rated input power with idle battery charger	< 1	W	
Power Factor for NiMH drivers	0.4...0.7C		From monitoring to charging state
Power Factor for LFP+ drivers	0.4...0.8C		From monitoring to charging state
Input voltage AC	202 ... 254	Vac	Performance range
Input voltage AC	198 ... 264	Vac	Safety operational range
Input frequency AC	47 ... 63	Hz	Performance range
Input frequency AC	45 ... 66	Hz	Safety operational range
Switched mains contact current	2.4	A	Maximum permissible current (Basic only)

Electrical output data

Specification item	Value	Unit	Condition
Regulation method	Constant Power		Full output voltage range
Output voltage SELV	15 ... 55	Vdc	
Output voltage max.	60	Vpk	U-OUT
Output voltage HV	45 ... 300	Vdc	
Output voltage max.	330	Vpk	U-OUT
Output LEDpower	2 ... 5	W	Depending on selected battery pack
I _{LED} max	2	A	Maximum LED current from AC driver *
Switch-over time AC > emergency mode	<500	ms	

* For temperature critical applications check design-in guide, verify temperatures for temperature critical applications.

Battery pack vs. output power

Specification item	12NC	Type	Capacity [mAh*]	Max. output power in EM mode [W**]	Standard discharge current [mA]	Maximum continuous discharge current [mA]	Discharge to pack voltage level [V]
TrustSight 3.6V 3cell 4000mAh battery NiMH	9290 016 52506	NiMH 3cell	4000	3 (2.7)	800	1300	3.0
TrustSight 4.8V 4cell 4000mAh battery NiMH	9290 016 52606	NiMH 4cell	4000	4 (3.7)	800	1300	4.0
TrustSight 6.0V 5cell 4000mAh battery NiMH	9290 016 52706	NiMH 5cell	4000	5 (4.7)	800	1300	5.0
TrustSight 3.2V 3cell 4500mAh battery LFP+	9290 034 19206	LFP 1S3P	4500	2 (2.1)	900	1350	2.5
TrustSight 6.4V 4cell 3000mAh battery LFP+	9290 034 19106	LFP 2S2P	3000	3 (2.9)	600	900	5.0
TrustSight 9.6V 6cell 3000mAh battery LFP+	9290 034 19006	LFP 3S2P	3000	5 (4.7)	600	900	7.5
TrustSight 6.4V 4cell 3000mAh LFP+ FRC	9290 034 23206	LFP FRC 2S2P	3000	3 (2.9)	600	900	5.0

LFP charging only between 0 and 55°C

* Batteries are sufficiently charged within 24 hours after being discharged.

** Min. 3 hours emergency duration for all driver-battery pack combinations

DALI

The TrustSight drivers with DALI functionality comply with DALI standard IEC62386 and IEC62386-202 (particular requirement for control gear - Self-contained emergency lighting). Commands supported are listed below:

Inhibit	Start identification
Query lamp failure	Query battery charge
Rest	Query test timing
Re_light_reset_inhibit	Query duration test result
Start function test	Query lamp emergency time
Start duration test	Query lamp total operation time
Stop test	Query emergency level
Reset function test done flag	Query rated duration
Reset duration test done flag	Query emergency mode
Reset lamp time	Query features
Store test execution timeout	Query Failure status
Store prolong time	Query Emergency status

DALI

The TrustSight drivers with DALI functionality support SimpleSet configuration. Several settings can be selected to configure the TrustSight driver.

Parameter	Default setting	Range	Description
Output power	100	50 ... 100%	Output power can be tuned as % of selected power
Region Selection	Europe	Europe Australia	
Duration test acceptance time	180	1 ... 240 minutes	Australia: 90 minutes
Selftest Mode	fixed	Fixed/DALI	Fixed mode gives standard FT/DT interval times
Function Test (FT) interval	28 days		Fixed mode
Duration Test (DT) interval	24 weeks		Fixed mode
Function Test (FT) interval	7 days		DALI mode, Configurable via DALI
Duration Test (DT) interval	52 weeks		DALI mode, Configurable via DALI
Battery Type	NiMH, LFP	Product dependent	Depends on the selected TrustSight type
Battery capacity	Auto Detect	Auto Detect NiMH 3cell for 3W NiMH 4cell for 4W NiMH 5cell for 5W LFP (1S3P) for 2W LFP (2S2P) for 3W LFP (3S2P) for 5W	The TrustSight detects the cell count automatically

In the Diagnostics tab of MultiOne the following parameters can be read out:

Parameter	Unit	Description
Lamp emergency time	Hours	
Lamp total operation time	Hours	
Last duration test time	Minutes	
Time since last duration test	Days	
Total number of discharge cycles	-	Number of complete battery discharges

Reset battery detection:

It is possible to set back the battery capacity (cell count) to autodetect, e.g. when the system is incorrectly configured. To reset the battery cell count there are two options:

- Direct change of the battery cell-count in the memory bank via NFC or DALI, e.g. in the final tester.
- Power cycle scheme to reset the driver to factory defaults:
 1. Apply mains voltage to mains input and 12Vdc to battery input simultaneously (or within 2s)
 2. After 1s the indicator LED starts fast flashing RED for 2s (4 times)
 3. Remove 12Vdc while flashing.
 4. After 1s the Indicator LED becomes steady GREEN for 2s.
 5. Disconnect mains voltage.

Use MultiOne (DALI / NFC) to change to Australia mode or by taking these steps:

1. Apply mains voltage to mains input and 12Vdc to battery input simultaneously (or within 2s)
2. After 1s the Indicator LED starts fast flashing RED for 2s (4 times)
3. Remove 12Vdc while flashing, then press the test button. Indicator LED will extinguish.
4. After 4s disconnect mains voltage.

Note: pressing the test button during the procedure will reset the device with Australia mode enabled, while not pressing the button will reset the device with Australia mode disabled.

If 12Vdc is applied for more than 3s or for less than 1.5s then a factory reset will not take place. Applying an invalid battery voltage will trigger a battery failure state (RED indicator LED), which when mains power is lost, will render the emergency function inactive (no emergency lighting).

To verify the successful execution: connect a valid battery and connect the driver to mains voltage for no more than 7 seconds to be sure the product stays in autodetect mode. Battery detection will take place within 7s. During this period, the indication will flash green.

To verify that Australia mode is active, press the test button for at least 10s while the battery is charging. The 30s functional test is started. When the test succeeds, the LED indicator is flashing fast green (for 5 days). This is specific for Australia mode.

Wiring & Connections

Specification item	Value	Unit	Condition
Built-in use: mains input wire cross-section	0.5 ... 1.5 20 ... 16	mm ² AWG	WAGO250, solid and stranded wire WAGO250, solid and stranded wire
Independent use: mains input wire cross-section	0.75 ... 1.5 18 ... 16	mm ² AWG	WAGO250, solid and stranded wire WAGO250, solid and stranded wire
Input wire strip length	8.5 ... 9.5	mm	
Independent use: input/output thick/thin cable diameter	6 ... 8 / 1.4 ... 2.0	mm	
Output wire cross-section	0.5 ... 1.5 20 ... 16	mm ² AWG	WAGO250, solid and stranded wire WAGO250, solid and stranded wire
Input wire strip length	8.5 ... 9.5	mm	
Maximum output cable length between driver and LED module	0.6	m	

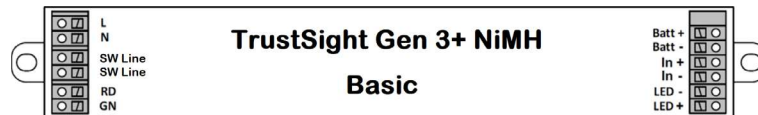
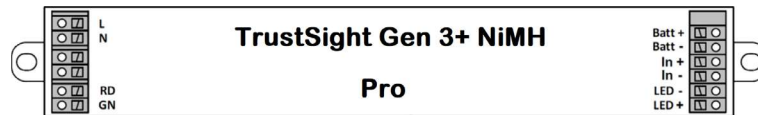
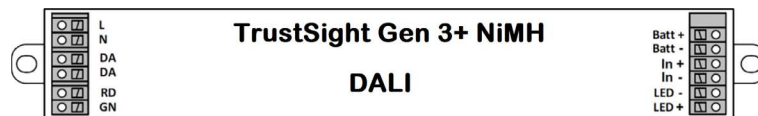
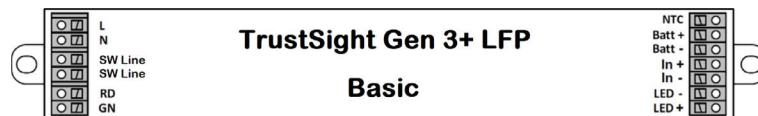
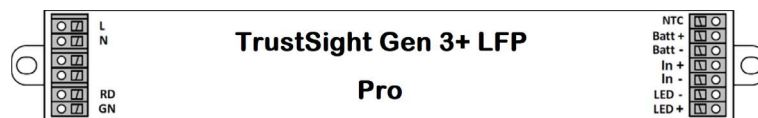
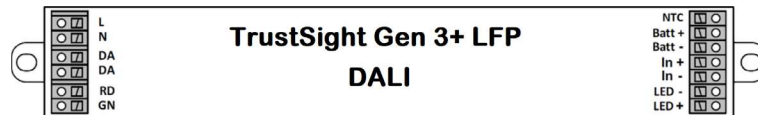

Insulation TrustSight Pro & DALI driver

	Mains	Battery	LED in/output	Status LED	NTC	DALI
Mains	NA					
Battery	Double	NA				
LED in/output	HV: Double, LV: SELV	Functional	NA			
Status LED	Double	No	Functional	NA		
NTC	Double	No	Functional	No	NA	
DALI	Double	Double	Double	Double	Double	NA

Insulation TrustSight Basic driver

	Mains	Battery	LED in/output	Status LED	NTC	SW line
Mains	NA					
Battery	Double	NA				
LED in/output	HV: Double, LV: SELV	Functional	NA			
Status LED	Double	No	Functional	NA		
NTC	Double	No	Functional	No	NA	
SW line	Basic	Supplementary	Supplementary	Supplementary	Supplementary	NA

Connection examples

Connection example with TrustSight HV with HV LED modules

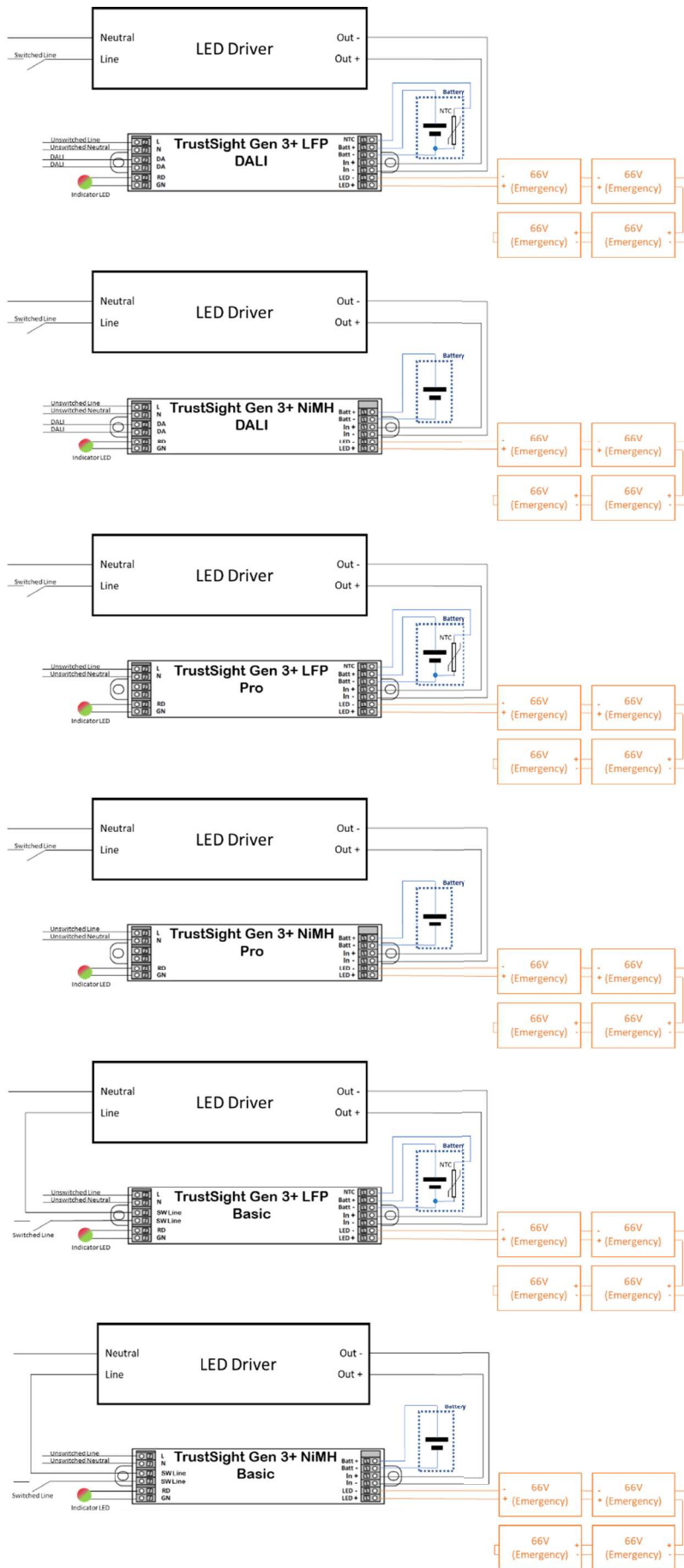

Connection examples

Connection example with TrustSight SELV with LV LED modules

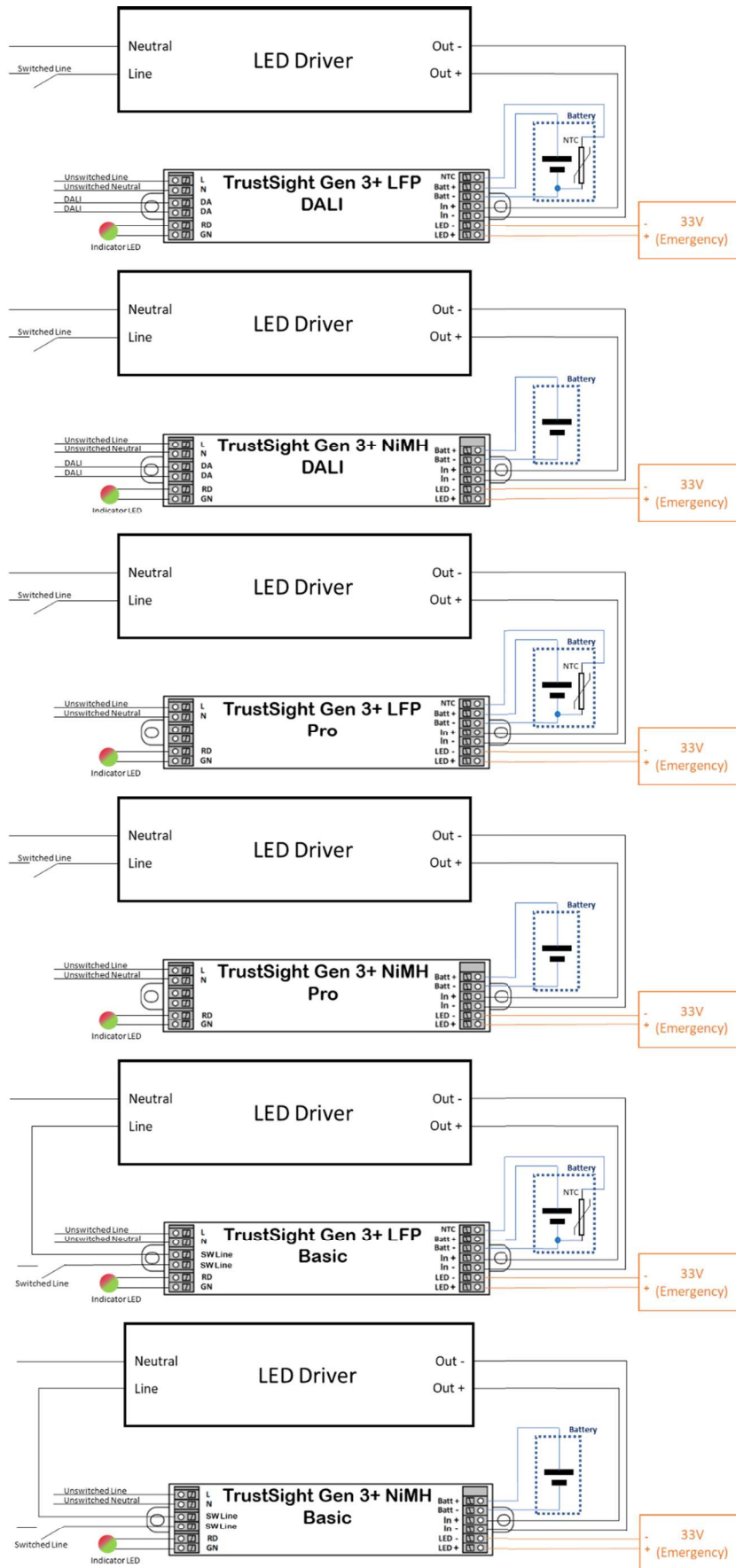

Warning: The TrustSight LV SELV driver does **not** support operation combined with non-SELV AC drivers.

Dimensions and weight

Specification item built-in version	Value	Unit	Condition
Length	205	mm	
Width	30	mm	
Height	21	mm	
Fixing hole diameter	4.1	mm	
Fixing hole distance	195.5	mm	
Weight	85	gram	

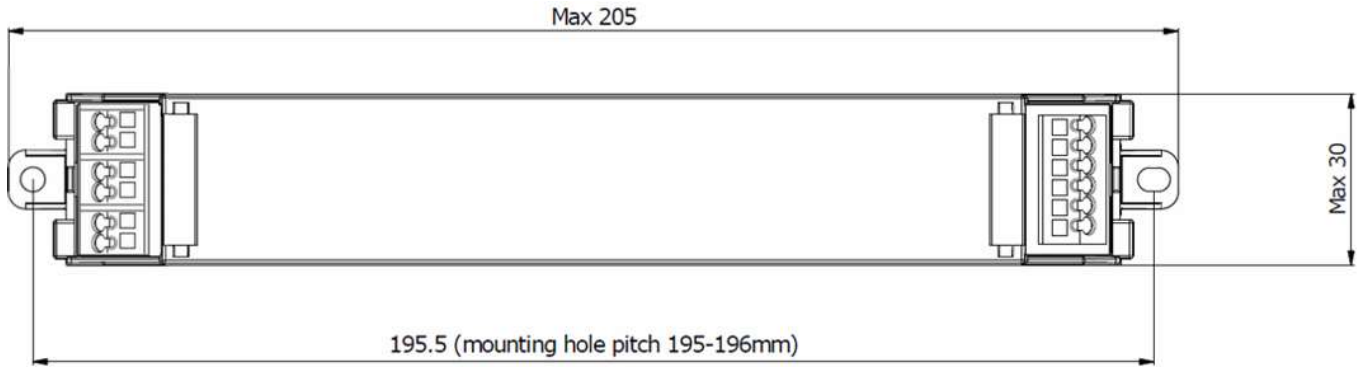

Specification item independent version	Value	Unit	Condition
Length	238	mm	
Width	30	mm	
Height	21	mm	
Fixing hole diameter	4.1	mm	
Fixing hole distance	195.5	mm	
Weight	100	gram	

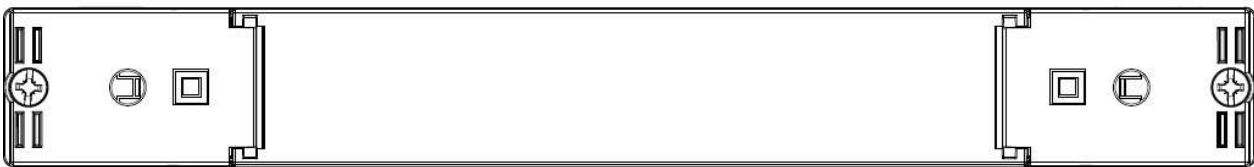
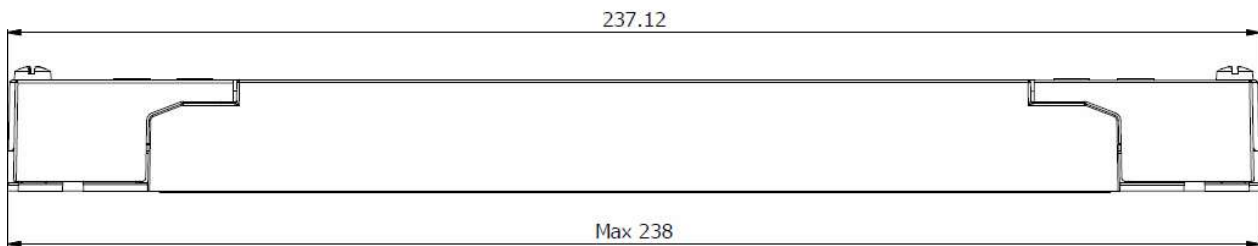

Battery dimensions

NiMH battery

3.6V 3cell 4000mAh battery NiMH Max height = 21mm	4.8V 4cell 4000mAh battery NiMH Max height = 21mm 65mm between pack-parts	6.0V 5cell 4000mAh battery NiMH Max height = 21mm 65mm between pack-parts

Parts List

Item	Quantity	Description
Mounting PCB	1, 2, 2	
Cell	3, 4, 5	HRH18700-4000T
Battery/PCB insulation wrap		PVC
Connector	1	Molex 5557-2P
Wire	2	UL1007, 20AWG



Warning:

The battery wires currently do **not** support independent operation with respect to compliance per IEC60598-2 clause 22.16 unless a fire and heat resistant sleeve is put around the wires (this sleeve is not included).

Battery dimensions

LFP battery

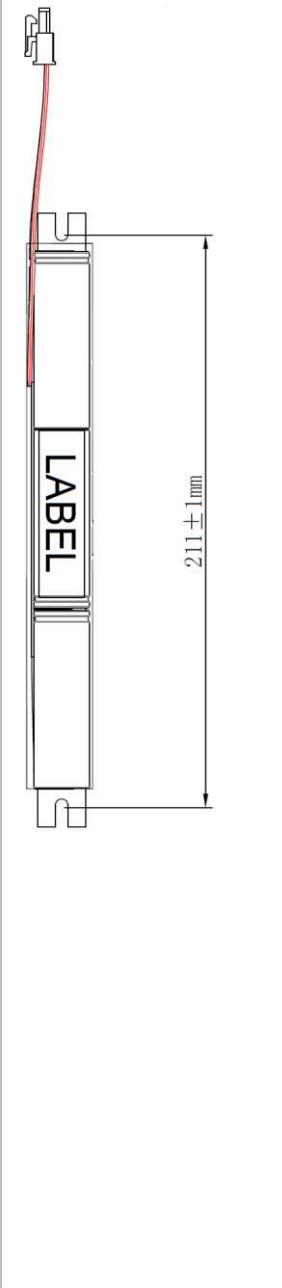
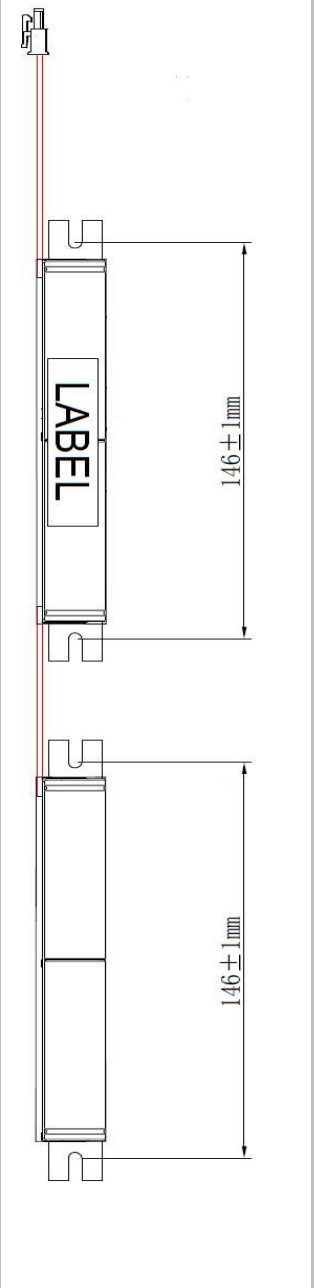
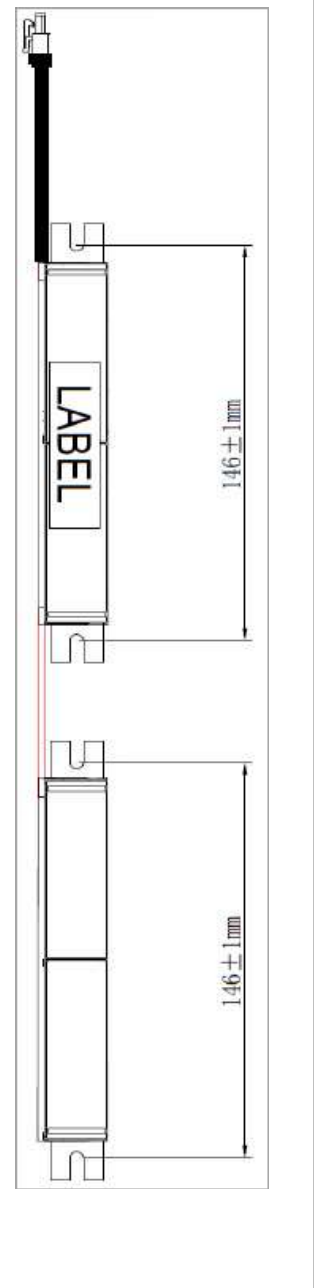
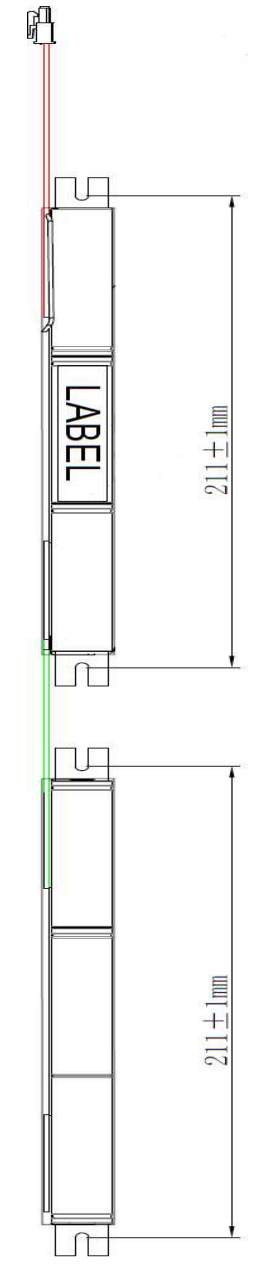
3.2V 3cell 4500mAh battery LFP Max height = 21mm	6.4V 4cell 3000mAh battery LFP Max height = 21mm 65mm between pack-parts	6.4V 4cell 3000mAh LFP FRC Max height = 21mm 65mm between pack-parts	9.6V 6cell 3000mAh battery LFP Max height = 21mm 65mm between pack-parts
			

Parts List

Item	Quantity	Description
Mounting PCB	1, 2, 2, 2	223X16
Cell	3, 4, 4, 6	FR18650E1500
Battery/PCB insulation wrap		PVC, white
Connector	1	Molex 5557-03R2
Connector (FRC type only)	1	Molex 50-29-1662, glow wire capable
Wire	3	UL1007, 20AWG
Cable (FRC type only)	1	UL2464, 3F x 18AWG



Warning:

The battery wires currently do **not** support independent operation with respect to compliance per IEC60598-2 clause 22.16 unless a fire and heat resistant sleeve is put around the wires (this sleeve is not included). A special LFP+ FRC battery pack (9290 034 23206) and LFP+ FRC battery harness (9290 034 23506) is available for that purpose.

Battery dimensions

Battery box (for SELV driver only)

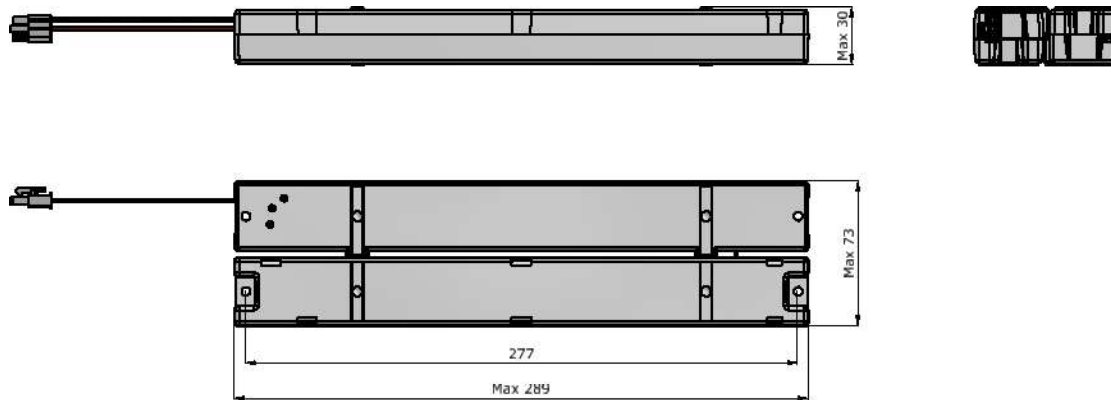

Temperature and humidity

Specification item	Value	Unit	Condition
Ambient temperature range driver	-20 ... +55	°C	
Ambient temperature range NiMH battery pack	0 ... +50	°C	
Ambient temperature range LFP+ battery pack	0 ... +55	°C	
Tcase-max driver	75	°C	During pulse charging regime. During charging of an empty or partially-charged battery: max. 90°C with duration of max. 24h
Tcase-max NiMH battery pack	55	°C	During charging
Tcase-max NiMH battery pack	50	°C	Lifetime 4 years in operation
Tcase-max LFP+ battery pack	55	°C	During charging
Tcase-max LFP+ battery pack	55	°C	Lifetime 6 year in operation
Maximum housing temperature driver	110	°C	In case of failure
Relative humidity range driver	10 ... 90	%	Non-condensing

Storage temperature and humidity

Specification item	Value	Unit	Condition
Storage Ambient temperature driver	-25 ... +70	°C	
Storage Ambient temperature NiMH battery pack	-20 ... +30	°C	Max. 6 months
Storage Ambient temperature LFP+ battery pack	-20 ... +25	°C	Max. 12 months
Relative humidity driver	5 ... 95	%	Non-condensing

Lifetime

Specification item	Value	Unit	Condition
Driver lifetime	70,000	hours	Measured temperature at Tc-point is Tcase- max. Maximum failures = 10%
NiMH battery	4	year	
NiMH battery warranty	1	year	As long as the cell is treated in accordance with the specification and/or handling precautions and prohibitions.
LFP+ battery	6	year	
LFP+ battery warranty	3	year	As long as the cell is treated in accordance with the specification and/or handling precautions and prohibitions.

TrustSight features / protections

Specification item	Value	Remark	Condition
Open load protection - LED output	Yes		
Short circuit protection - LED output	Yes		
Hot wiring - LED output	No		
Suitable for luminaire Insulation Class	I and II		Acc. IEC60598-1
Open load protection - battery input	Yes		Automatic recovering
Short circuit protection - battery input	Yes		Automatic recovering
Reverse polarity protection - battery input	Yes		Automatic recovering

Inrush current and fusing

Specification item	Value	Unit	Condition
Inrush current I_{peak}	5	A	Input voltage 230Vac
Inrush current T_{width}	110	μ s	Input voltage 230Vac, measured at 50% I_{peak}
Recommended max. number of drivers / MCB 16A type B	200		Indicative value

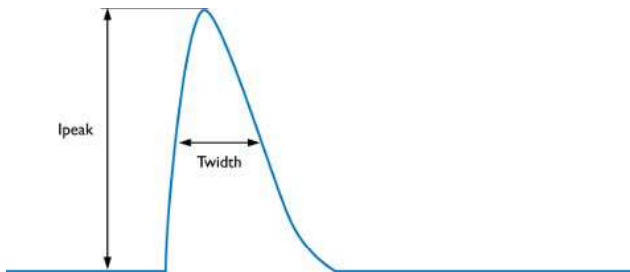

Touch current

Specification item	Value	Unit	Condition
Typical touch current (parasitical)	< 0.7	mApk	To all accessible parts, LED module contribution not included

Surge immunity

Specification item	Value	Unit	Condition
Mains surge immunity (diff. mode)	1	kV	L-N, acc. IEC61000-4-5, 2 Ohm 1.2/50 μ s
Mains surge immunity (comm. mode)	2	kV	L/N - other, acc. IEC61000-4-5, 12 Ohm 1.2/50 μ s

Certificates and standards

Compliance and approval	Generated disturbances (EMI/EMC)
EN 55015 A2/CISPR15	Conducted EMI 9 kHz-30 MHz
EN 55015 A2/CISPR15	Radiated EMI 30 MHz-300 MHz
IEC 61000-3-2	Limits for mains input current harmonics
IEC 61000-3-3	EMC – Limitation of voltage fluctuation and flicker in low-voltage supply systems for equipment rated up to 16 A
Immunity	
IEC / EN 61547	Equipment for general lighting purposes – EMC immunity requirements
IEC / EN 61000-4-2	Electrostatic Discharge
IEC / EN 61000-4-3	Radiated radio frequency, electromagnetic field immunity
IEC / EN 61000-4-4	Electrical fast transient/burst immunity
IEC / EN 61000-4-5	Surge immunity
IEC / EN 61000-4-6	Conducted disturbances induced by RF fields
IEC / EN 61000-4-11	Voltage dips, short interrupts, voltage variations
Performance	
IEC 62384	DC or AC supplied electronic control gear for LED modules - Performance requirements
IEC 62386	Digital Addressable Lighting Interface (DALI)
Safety standards	
IEC / EN / AS/NZS 61347-1	General and safety requirements
IEC / EN / AS/NZS 61347-2-13	LED Particular requirements for DC or AC supplied electronic control gears for LED modules
Emergency standards	
IEC / EN 61347-2-7	Particular requirements for DC supplied electronic ballasts for emergency lighting
IEC / EN 62034	Automatic test systems for battery powered emergency escape lighting

RCM independent control gear classification

Regulation AS/NZS 60598.2.2	Applies when the control gear is built inside constructions	
Clearance type	Description	Distance
Height clearance to building element (HCB)	Minimum distance between the top of the control gear and any building element above it	5mm
Minimum insulation clearance (MIC)	Minimum distance between the top of the control gear and the building insulation above it	5mm
Side clearance to building element (SCB)	Minimum distance between the side of the control gear and any building element	5mm
Side clearance to insulation (SCI)	Minimum distance between the side of the control gear and any building insulation	5mm

RISK OF FIRE**BUILDING INSULATION MUST NOT COVER THE CONTROL GEAR**

Please refer to the driver certificates for more details at www.philips.com/oem.



©2023 Signify Holding, IBRS 10461, 5600 VB, NL. All rights reserved.
 UK importer address: Signify Commercial UK Limited, 3, Guildford Business Park, GU2 8XG

The information provided herein is subject to change without notice. Signify does not give any representation or warranty as to the accuracy or completeness of the information included herein and shall not be liable for any action in reliance thereon. The information presented in this document is not intended as any commercial offer and does not form part of any quotation or contract, unless otherwise agreed by Signify. Philips and the Philips Shield Emblem are registered trademarks of Koninklijke Philips N.V. All other trademarks are owned by Signify Holding or their respective owners.

Date of release: October 17, 2023 v1.1
www.philips.com/oem