



EM converterLED BASIC 90 V Emergency lighting LED Driver

Product description

- Emergency lighting LED Driver for manual testing
- For LED modules with a forward voltage of 40 – 97 V
- SELV for output voltage < 120 V DC
- Low-profile casing (21 x 30 mm cross-section)
- For luminaire installation

Properties

- Non maintained operation
- 1 or 3 h rated duration
- Operating time selectable with plug (duration link)
- Compatible with all dimmable and non-dimmable constant current LED Drivers (see LED Driver compatibility, page 5)
- 3-pole technology: 2-pole LED module changeover and delayed power switching for the LED Driver
- Automatic shutdown of output if LED load is out of range
- Constant power output
- Maximum light output for all LED modules
- Electronic charge system
- Deep discharge protection
- Short-circuit-proof battery connection
- Polarity reversal protection for battery

Batteries

- High-temperature cells
- NiCd or NiMH batteries
- D, Cs or 7/5 Cs cells



Standards, page 7

Wiring diagrams and installation examples, page 8

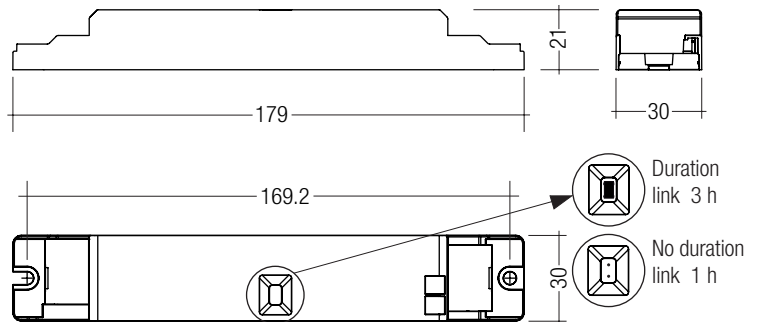
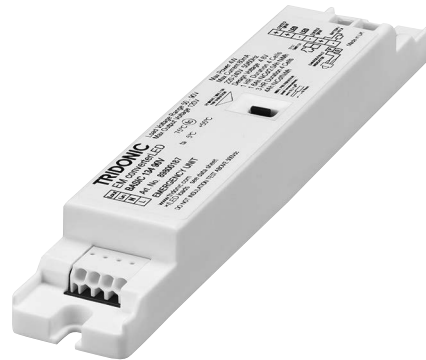

Note: LED Driver supplied with duration link in 3 hours position. Remove duration link for 1 hour duration. Duration link must be set before battery and mains connection. The EM converterLED BASIC 135 NiCd is supplied without a duration link. The duration is set to 3 hours and cannot be changed.

Technical data

Rated supply voltage	220 – 240 V
Mains frequency	50 / 60 Hz
Typ. λ (at 230 V, 50 Hz)	0.6
LED module forward voltage range	40 – 97 V
Output current	see page 4
Time to light	< 0.25 s from detection of emergency event
Overvoltage protection	320 V (for 1 h)
Maximum output voltage	120 V
Battery charging time	20 h ^①
Ambient temperature range t_a	-5 ... + 55 °C
Max. casing temperature t_c	70 °C
Mains voltage changeover threshold	according to EN 60598-2-22
Type of protection	IP20

^① 16 h battery charging time for 2 h emergency lighting function according to AS 2293.

Ordering data

Type	Article number	Rated duration	Number of cells	Packaging, carton	Packaging, pallet	Weight per pc.
EM converterLED BASIC 104 90V	89800187	1/3 h	4	10 pc(s).	800 pc(s).	0.078 kg
EM converterLED BASIC 105 90V	89800188	1/3 h	5	10 pc(s).	800 pc(s).	0.077 kg
EM converterLED BASIC 135 NiCd 90V	89800189	3 h	5	10 pc(s).	800 pc(s).	0.077 kg

Specific technical data

Type	Rated duration	Max. output power	Mains current in charging operation	Rated power in charging operation
EM converterLED BASIC 104 90V	1 h	3.8 W	27 mA	3.0 W
	3 h	3.8 W	35 mA	4.0 W
EM converterLED BASIC 105 90V	1 h	4.8 W	27 mA	3.0 W
	3 h	4.8 W	35 mA	4.5 W
EM converterLED BASIC 135 NiCd 90V	3 h	1.9 W	27 mA	3.0 W

RoHS

ACCESSORIES

Test switch EM3

Product description

- For connection to the emergency lighting unit
- For checking the device function
- Plug connection



Ordering data

Type	Article number	Packaging, bag	Packaging, carton	Weight per pc.
Test switch EM 3	89899956	25 pc(s).	200 pc(s).	0.013 kg

ACCESSORIES

Status indication green LED

Product description

- A green LED indicates that charging current is flowing into the battery
- Plug connection



Ordering data

Type	Article number	Packaging, bag	Packaging, carton	Weight per pc.
LED EM green, 1.0 m CON	89800269	25 pc(s).	200 pc(s).	0.015 kg
LED EM green, HO 1.0 m CON	89800271	25 pc(s).	200 pc(s).	0.015 kg
LED EM green, 0.6 m CON	89800472	25 pc(s).	200 pc(s).	0.005 kg
LED EM green, HO 0.6 m CON	89800473	25 pc(s).	200 pc(s).	0.005 kg
LED EM green, 0.3 m CON	89800270	25 pc(s).	200 pc(s).	0.005 kg
LED EM green, HO 0.3 m CON	89800272	25 pc(s).	200 pc(s).	0.005 kg

Battery selection

EM converterLED BASIC, 1 / 3 h

		Type	EM converterLED BASIC 104 90V		EM converterLED BASIC 105 90V		EM converterLED BASIC 135 90V		
		Article no.	89800187		89800188		89800189		
		Cells	4 cells		5 cells		5 cells		
		Duration	1 h	3 h	1 h	3 h	3 h		
Technology and Design capacity	Number of cells	Type	Article no.		Assignable batteries				
NiCd 1.6Ah Cs cells [®]	stick	1 x 4 Accu-NiCd C 4A	89899692	•					
	stick	1 x 5 Accu-NiCd C 5A	89899695		•			•	
	stick + stick	2 + 2 Accu-NiCd C 4C	89899694	•					
	stick + stick	3 + 2 Accu-NiCd C 5C	89899697		•			•	
	side by side	4 x 1 Accu NiCd C 4B	89899693	•					
	side by side	5 x 1 Accu NiCd C 5B	89899696			•			•
NiCd 4Ah D cells [®]	stick	1 x 4 Accu-NiCd 4A 55	89800089		•				
	stick	1 x 5 Accu-NiCd 5A	89895973			•			
	stick + stick	2 + 2 Accu-NiCd 4C	89895978		•				
	stick + stick	3 + 2 Accu-NiCd 5C 55	89800090				•		
	side by side	4 x 1 Accu NiCd 4B	89895977		•				
NiMH 2Ah Cs cells [®]	stick	1 x 4 Accu-NiMH C 4A	89899700	•					
	stick	1 x 5 Accu-NiMH C 5A	89899703			•			•
	side by side	5 x 1 Accu-NiMH C 5B	89899704			•			•
NiMH 4Ah 7/5 Cs cells [®]	stick	1 x 4 Accu-NiMH 4 Ah C 4A	89899850		•				
	stick	1 x 5 Accu-NiMH 4Ah C 5A	89899851				•		
	stick + stick	3 + 2 Accu-NiMH 4Ah C 5C	89899978				•		

[®] 50 °C batteries also available (see separate datasheet at www.tridonic.com)

[®] Maximum battery temperature see page 5, technical data batteries.

Battery charge / discharge data

EM converterLED BASIC, 1 / 3 h

Type	EM converterLED BASIC 104 90V		EM converterLED BASIC 105 90V		EM converterLED BASIC 135 90V
	Article no.	89800187	89800188	89800189	89800189
Cells	4 cells		5 cells		5 cells
Duration	1 h	3 h	1 h	3 h	3 h
Charging current	105 mA	210 mA	105 mA	210 mA	105 mA
Discharge current	750 – 960 mA	750 – 960 mA	750 – 960 mA	750 – 960 mA	290 – 370 mA

Typ. LED current/voltage characteristics

The LED current in emergency mode is automatically adjusted by the EM converterLED module based on the total forward voltage of the LED modules connected and the associated battery.

EM converterLED BASIC 104 90V

Article number: 89800187

4.8 V battery voltage

750 – 960 mA battery discharge current (tolerance)

EM converterLED BASIC 105 90V

Article number: 89800188

6.0 V battery voltage

750 – 960 mA battery discharge current (tolerance)

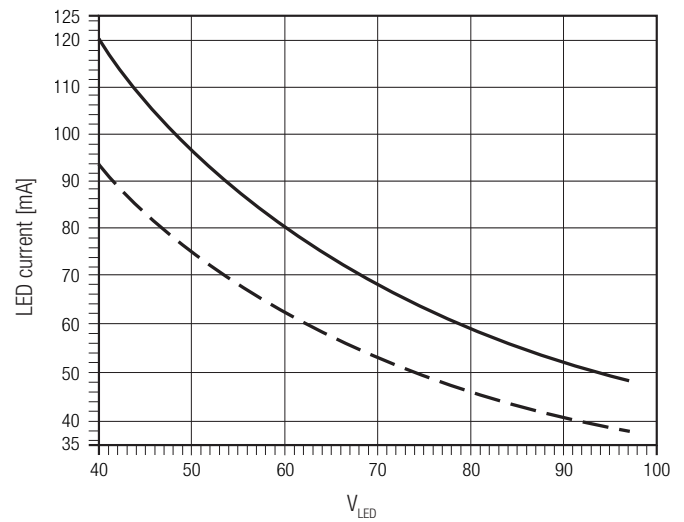
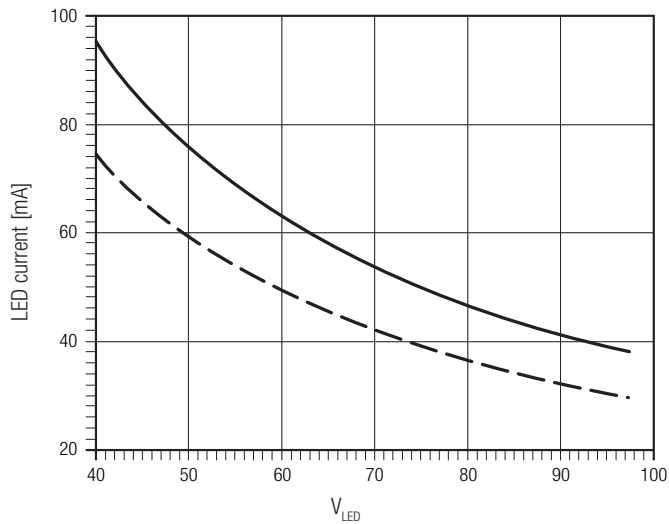

LED peak current at start in emergency mode – 4 cells

Voltage	Inrush current	Duration
49.6 V	190 mA	15.0 ms
52.1 V	187 mA	14.2 ms
54.6 V	184 mA	12.7 ms
57.2 V	182 mA	12.2 ms
62.3 V	175 mA	11.3 ms
64.8 V	171 mA	10.8 ms
67.4 V	167 mA	10.2 ms
72.5 V	159 mA	9.4 ms
77.5 V	154 mA	9.0 ms
80.1 V	149 mA	8.3 ms
82.6 V	146 mA	8.3 ms
85.1 V	144 mA	8.1 ms
87.6 V	139 mA	7.8 ms
90.2 V	136 mA	8.0 ms

LED peak current at start in emergency mode – 5 cells

Voltage	Inrush current	Duration
49.9 V	222 mA	12.2 ms
52.5 V	218 mA	10.6 ms
55.0 V	209 mA	9.9 ms
57.6 V	205 mA	9.7 ms
62.7 V	194 mA	8.5 ms
65.2 V	189 mA	7.9 ms
67.7 V	184 mA	7.3 ms
72.8 V	178 mA	7.0 ms
77.9 V	169 mA	6.9 ms
80.5 V	166 mA	6.4 ms
83.0 V	163 mA	6.2 ms
85.6 V	161 mA	5.8 ms
88.1 V	159 mA	5.3 ms
90.6 V	155 mA	5.2 ms

Note: LED peak current measured at the max. battery discharge current and at a max. battery voltage of 6 V (4 cells) or 7.5 V (5 cells).

EM converterLED BASIC 135 90V
Article number: 89800189
6.0 V battery voltage
290 – 370 mA battery discharge current (tolerance)

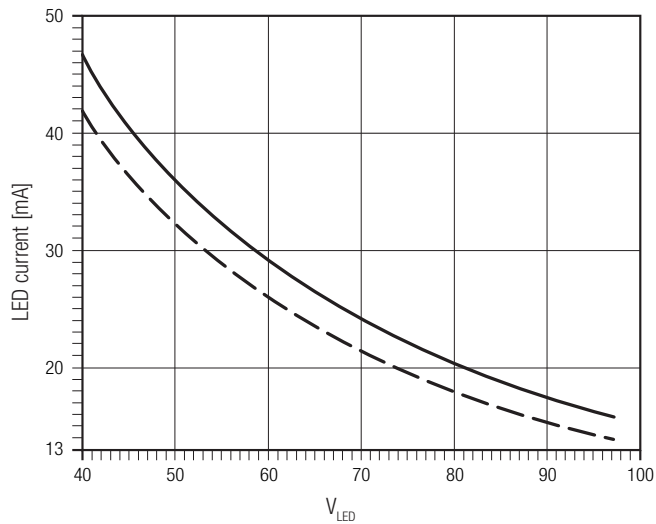

--- LED current at nominal battery voltage and min. battery discharge current

— LED current at nominal battery voltage and max. battery discharge current

LED peak current at start in emergency mode – 5 cells

Voltage	Inrush current	Duration
51.1 V	162 mA	10.2 ms
53.8 V	154 mA	9.2 ms
56.3 V	150 mA	9.0 ms
58.8 V	148 mA	8.5 ms
61.3 V	143 mA	8.2 ms
66.3 V	132 mA	7.7 ms
68.8 V	126 mA	7.2 ms
71.3 V	125 mA	6.2 ms
76.4 V	112 mA	4.7 ms
78.8 V	110 mA	4.2 ms
81.3 V	105 mA	4.1 ms
83.8 V	100 mA	3.8 ms
86.3 V	97 mA	3.2 ms
88.8 V	91 mA	3.1 ms
91.3 V	88 mA	3.0 ms

Isolation and electric strength testing of luminaires

Electronic LED Drivers can be damaged by high voltage. This has to be considered during the routine testing of the luminaires in production.

According to IEC 60598-1 Annex Q (informative only!) or ENEC 303-Annex A, each luminaire should be submitted to an isolation test with 500 V_{DC} for 1 second. This test voltage should be connected between the interconnected phase and neutral terminals and the earth terminal. The isolation resistance must be at least 2 MΩ.

As an alternative, IEC 60598-1 Annex Q describes a test of the electrical strength with 1,500 V_{AC} (or 1,414 x 1,500 V_{DC}). To avoid damage to the electronic devices this test **must not be conducted**.

Technical data batteries**Accu-NiCd**

Case temperature range

to ensure 4 years design life

4.2 / 4.5 Ah D

1.6 Cs

Battery voltage/cell

Capacity D

Capacity Cs

Max. short term temperature (reduced life-time)

Max. number discharge cycles

+5 °C to +55 °C

+5 °C to +50 °C

1.2 V

4.2 / 4.5 Ah

1.6 Ah

70 °C

4 cycles per year plus

4 cycles during

commissioning

5 pcs. per carton

Packing quantity

Accu-NiMh

Case temperature range

to ensure 4 years design life

2.0 Ah Cs

4.0 Ah Cs

Battery voltage

Capacity

Max. short term temperature (reduced life-time)

Max. number discharge cycles 2.0 Ah Cs

+5 °C to +55 °C

+5 °C to +40 °C

1.2 V

2.0 Ah / 4.0 Ah

70 °C

4 cycles per year plus

4 cycles during

commissioning

2 cycles per year plus

4 cycles during

commissioning

5 pcs. per carton

Max. number discharge cycles 4.0 Ah Cs

Packing quantity

LED Driver compatibility

The EM converterLED emergency unit use 3 pole technology and is compatible with most LED Drivers on the market, however it is important to check that the rating of the LED Driver does not exceed the values specified below:

- The max. allowed output current rating of the associated LED Driver is 2.4 A peak (current rating of switching relays of EM converterLED)
- The max. allowed inrush current rating of the associated LED Driver is 60 A peak for 1 ms (inrush current rating of switching relay of EM converterLED)
- The max. allowed output voltage of the associated LED Driver applied to the EM converterLED output is 450V (voltage withstand between adjacent contact of the single switching relay of the EM converterLED)
- The max. allowed power rating of the associated LED Driver is 80 W in operation

Life-time

Average life-time 50,000 hours under rated conditions with a failure rate of less than 10 %. Average failure rate of 0.2% per 1000 operating hours.

Maximum lead length

LED 3 m^①

Status indication LED 1 m

Batteries 1.3 m

^① Note: The length of LED leads to the LED module must not be exceeded. Note that the length of the EM converterLED leads is added to the length of the leads from the LED Driver to the EM converterLED module when considering max. permitted lead length of the LED Driver. Leads should always be kept as short as possible.

Mechanical details

Casing manufactured from polycarbonate.

Glow-wire test according to EN 61347-1 with increased temperature of 960 °C passed.

LED status indicator

- Green
- Mounting hole 6.5 mm dia
- Lead length 0.3 m / 1.0 m
- Insulation rating: 90 °C
- Plug connection

Test switch

- Mounting hole 7.0 mm dia
- Lead length 0.55 m
- Plug connection

Battery leads

- Quantity: 1 red and 1 black
- Length: 1.3 m
- Wire type: 0.5 mm² solid conductor
- Insulation rating: 90 °C

Battery end termination

Push on 4.8 mm receptacle to suit battery
spade fitted with insulating cover

Module end termination

8.0 mm stripped insulation

Two-piece batteries are supplied with a 200 mm lead with 4.8 mm receptacle at each end and insulating covers to connect the separate sticks together.

Electrical connections

Wiring

LED module/LED Driver/supply

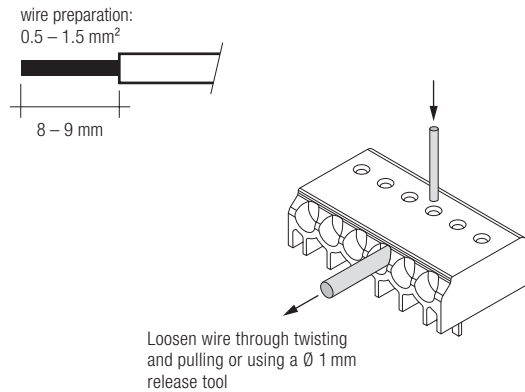

Duration link selection

Duration	Usage duration link
3 h	 With link
1 h	 Without link

Emergency lighting LED Driver supplied with duration link in 3 hours position.

The position of the link will only be read on first power up. If it is changed afterwards both the battery and mains supply must be disconnected for 10 seconds to enable the EM converterLED to read the new link position on reconnection of the battery and mains. It will lead to a false battery failure indication if the link is changed after installation without this reset.

Wiring type and cross section

Solid wire with a cross section of 0.5 – 1.5 mm². Strip 8 – 9 mm of insulation from the cables to ensure perfect operation of terminals.

Batteries

Connection method: 4.8 x 0.5 mm spade tag welded to end of cell.

For stick packs this connection is accessible after the battery caps have been fitted.

To inhibit inverter operation disconnect the batteries by removing the connector from the battery spade tag.

For battery data see separate data sheet.

Phase to phase isolation

The use of different phases for switched line and unswitched line is permitted.

Standards

- according to EN 50172
- according to EN 60598-2-22
- EN 61347-1:2008+A2:2013
- EN 61347-2-13
- EN 61347-2-7
- EN 55015
- EN 61000-3-2
- EN 61000-3-3
- EN 61547
- EN 60068-2-64
- EN 60068-2-29
- EN 60068-2-30
- EN 62384

Meaning of marking

Double or reinforced insulation for built-in electronic LED Drivers

Wiring guidelines

- The LED terminals, battery, indicator LED and test switch terminals are classified as SELV (output voltage < 120 V DC). Keep the wiring of the input terminals separated from the wiring of the SELV equivalent terminals or consider special wiring (double insulation, 6 mm creepage and clearance) when these connections should be kept SELV.
- The output to the LED is DC but has high frequency content, which should be considered for good EMC compliance.
- LED leads should be separated from the mains connections and wiring for good EMC performance.
- Maximum lead length on the LED terminals is 3 m. For a good EMC performance keep the LED wiring as short as possible.
- Maximum lead length for the Test switch and Indicator LED connection is 1 m. The test switch and Indicator LED wiring should be separated from the LED leads to prevent noise coupling.
- Battery leads are specified with 0.5 mm cross section and a length of 1.3 m

To ensure that a luminaire containing LED emergency units complies with EN 55015 for radio frequency conducted interference in both normal and emergency mode it is essential to follow good practice in the wiring layout.

Within the luminaire the switched and unswitched 50 Hz supply wiring must be routed as short as possible and be kept as far away as possible from the LED leads. Through wiring may affect the emc performance of the luminaire.

The length of LED leads must not be exceeded. Note that the length of the EM converterLED leads is added to the length of the leads from the LED Driver to the EM converterLED module when considering max. permitted lead length of the LED Driver.

Maximum loading of automatic circuit breakers

Automatic circuit breaker type	B10	B13	B16	B20	C10	C13	C16	C20	Inrush current	
Installation Ø	1.5 mm ²	1.5 mm ²	1.5 mm ²	2.5 mm ²	1.5 mm ²	1.5 mm ²	1.5 mm ²	2.5 mm ²	I _{max}	time
EM converterLED 104 BASIC 90V	90	130	130	130	180	260	260	260	10 A	120 µs
EM converterLED 105 BASIC 90V	90	130	130	130	180	260	260	260	10 A	120 µs

Wiring diagrams

One or more LED modules with a total forward voltage of 40 to 97 V can be connected to the EM converterLED 90V module. These LED module(s), marked with "Emergency" are operated in emergency mode from the associated battery. In normal mains mode all LED modules are operated by the LED mains LED Driver

EM converterLED BASIC with one LED module for non-maintained emergency operation

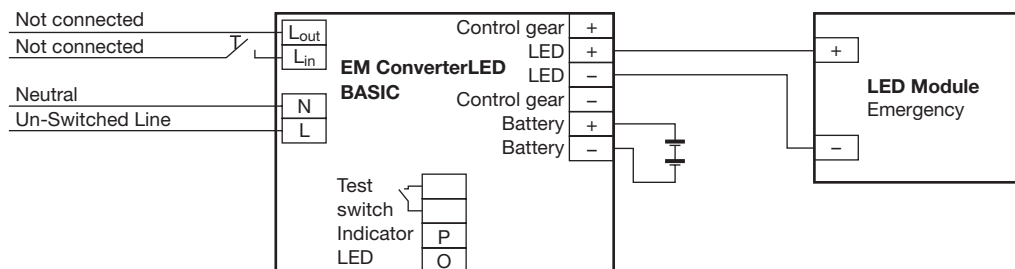

EM converterLED BASIC with a standard LED Driver and one LED module for mains and emergency operation

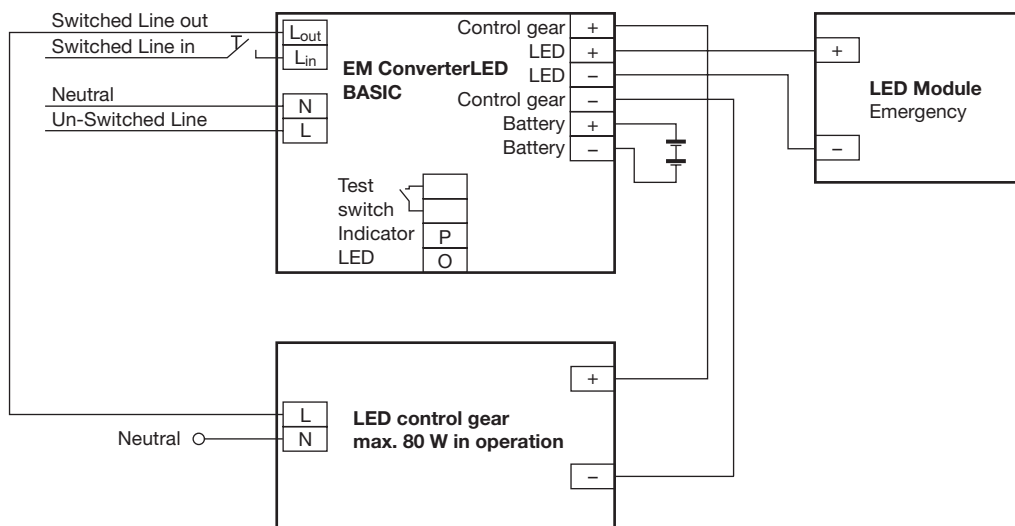

EM converterLED BASIC with a standard LED Driver and series operation of LED modules

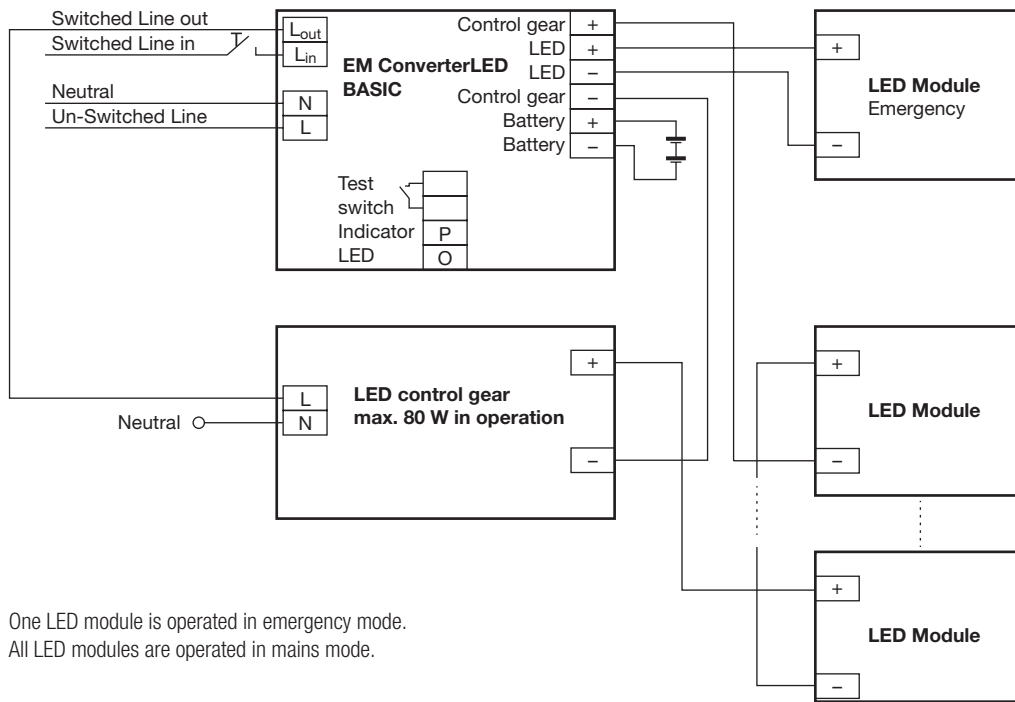

One LED module is operated in emergency mode.
All LED modules are operated in mains mode.

EM converterLED BASIC with a standard LED Driver and series operation of LED modules

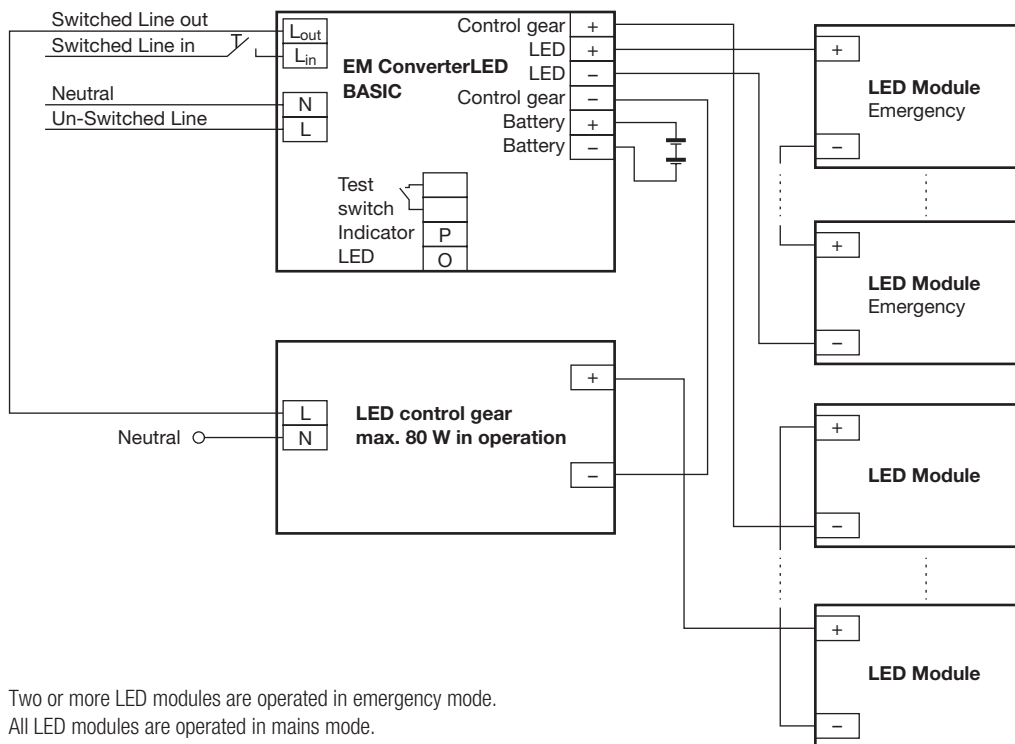

Two or more LED modules are operated in emergency mode.
All LED modules are operated in mains mode.

EM converterLED BASIC with a standard LED Driver and parallel operation of LED modules

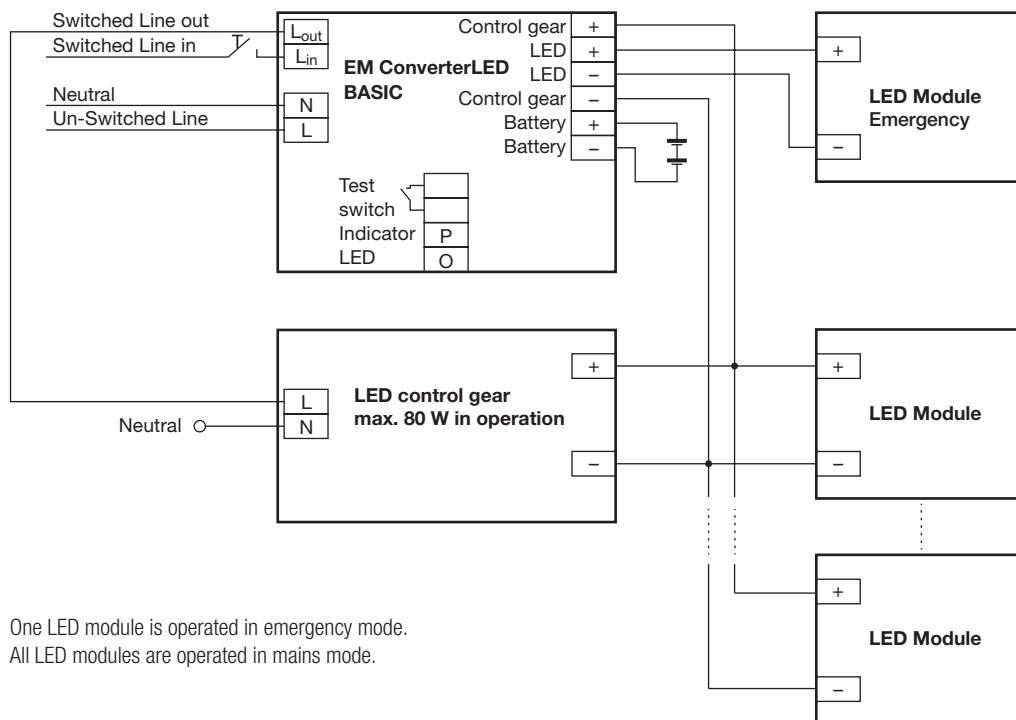

One LED module is operated in emergency mode.
All LED modules are operated in mains mode.

EM converterLED BASIC with a standard LED Driver and parallel operation of LED modules

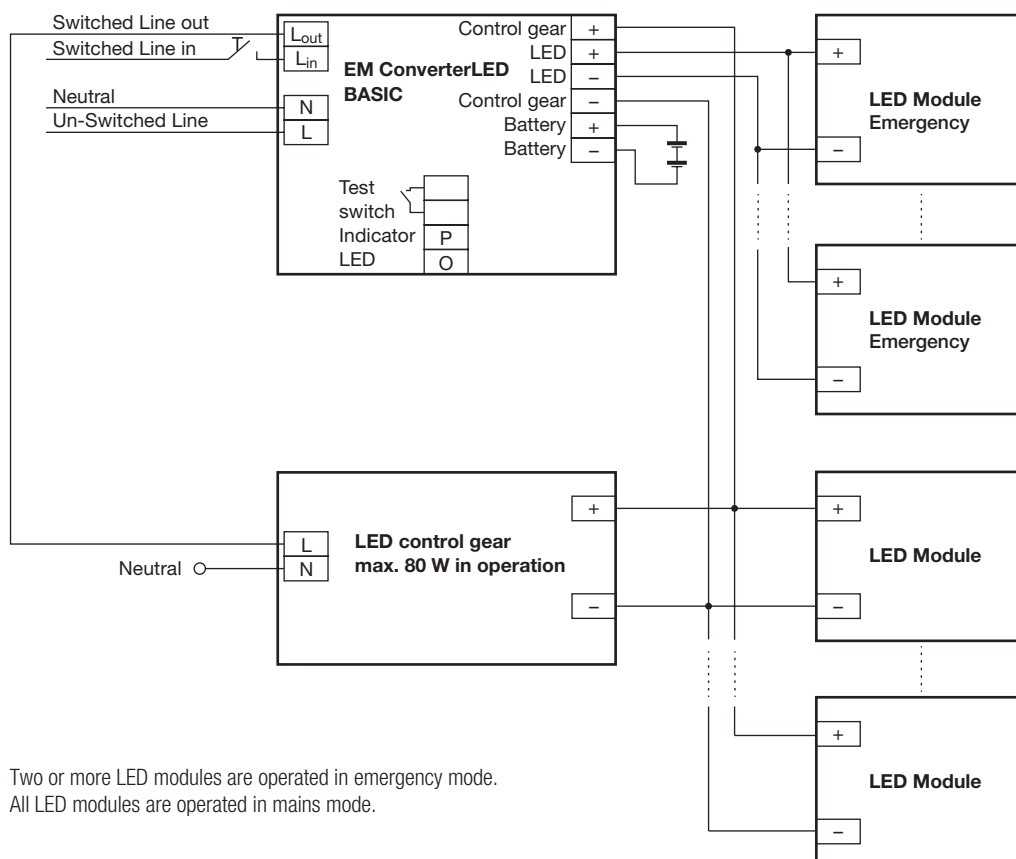

Two or more LED modules are operated in emergency mode.
All LED modules are operated in mains mode.