

Safety luminaire

LED emergency luminaire for escape route lighting with min. 1 lux compliant to EN 1838; Room height 2.2 to 10 m; high performance (HP) version enables wider luminaire spacing and applications with higher illuminances (e.g. 5 lux, 1 footcandle); 2 high power LEDs, neutral white 4,000 K; lens made of polycarbonate; optimum thermal management via heat sink; Ceiling recessed luminaire for 68 mm ceiling cut-out and ceiling thickness from 1 - 25 mm; tool-free rapid luminaire installation through specially shaped retaining springs; tool-free replacement of battery and control unit; Cover ring diecast aluminium, powder-coated; housing colour white (close to RAL9016); Polypropylene (PP) gearbox for installation in ceiling recess; Luminaire with local battery supply for 1 h emergency lighting in maintained or non-maintained mode, with automatic test (auto-test) via the luminaire, optional central monitoring via DALI, display of luminaire status via status LED; NFC interface for addressing, configuration and maintenance via PROset Pen (article no.: 22170290) or PROset app; addressing also alternatively possible visually or via EZ-addressing; Maintained and non-maintained mode: +5°C to +30°C; power supply: 220-240 V AC (+/- 10%), 50-60 Hz; Luminaire input power: 8.2 W (with battery fast-charge in maintained mode); typical power (without battery charge): 3,5 W in maintained mode / 1,1 W in non-maintained mode; Non-maintained and maintained mode settable via jumper and NFC interface; IP40; SC1; Luminaire wired with halogen-free and silicone-free leads. Suitable for installing in concrete casting surround (separately ordered); Plug-in terminals for through-wiring up to 2.5 mm²; Impact strength: IK04; Dimensions: Ø85 x 4 mm; weight: 0.44 kg; Robust, integrated battery with 3-year warranty. Valid according to terms of the manufacturer's warranty, available at https://www.zumtobel.com/media/downloads/Garantiebedingungen_EN.pdf; Battery warranty invalid if installation takes place three (3) months after delivery EXW (Incoterms 2010)

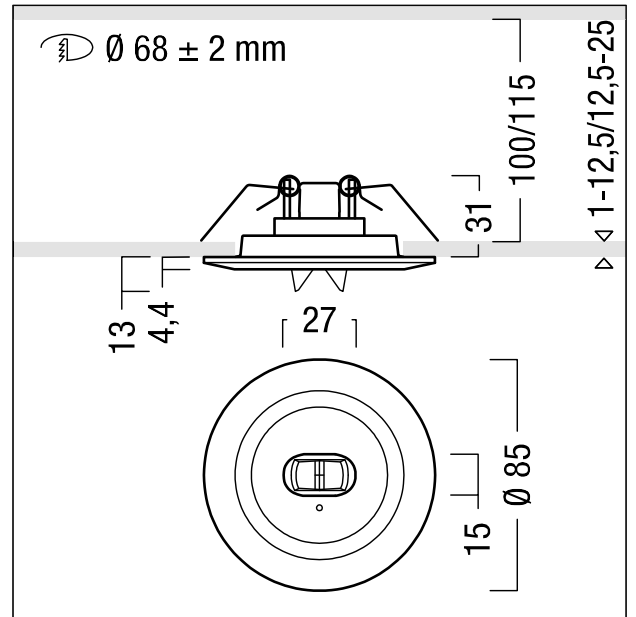

ZS_RES_F_PRO_MRCR_E1D_ESC_HP_WH.jpg



ZS_RES_M_PRO_MRCR.wmf

Light Distribution

STD - standard

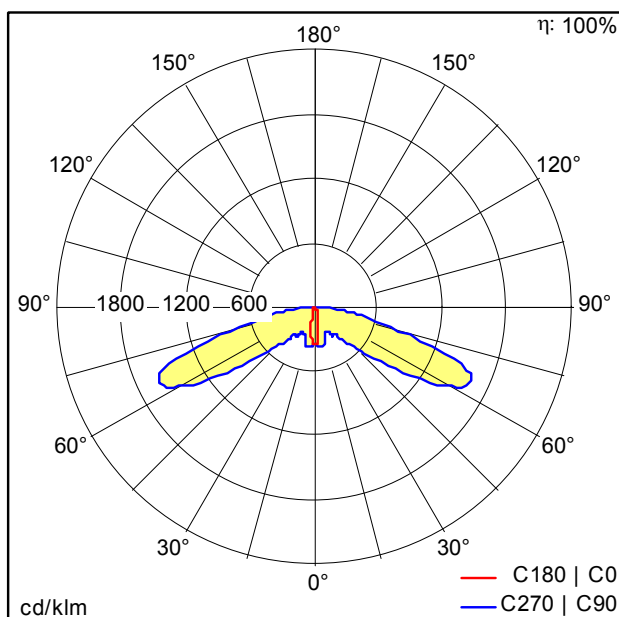

D43503_RESCLITE_PRO_MRCR_ESC_HP_E1D_WH.Idt

Please also consult the additional information on the next page

- Light Source: LED
- Luminaire luminous flux*: 487 lm
- Total emergency luminous flux: 487 lm
- Luminaire efficacy*: 59 lm/W
- Colour Rendering Index min.: 70
- Ballast: 1 x 89800524 DRV EM TR LBS P ST DA 5W 2
- Chromaticity tolerance (initial MacAdam): 5
- Rated median useful life*: L95 100000h at 25°C
- Luminaire input power*: 8.2 W Power factor = 0.84
- Standby Power*: 1.2 W
- Charging power: 2.27 W
- Service life rating: 1 h
- Maintenance category CIE 97: D - Enclosed IP2X

RESCLITE PRO MRCR recessed ceiling IP20-40



ZUMTOBEL

RESCLITE PRO MRCR ESC HP E1D WH

42185683

Safety luminaire