

Suspended LED luminaire

Suspended LED luminaire for direct and indirect illumination with UGR<19. Gentle, soft and glare-free lighting for office and education applications with opal diffuser made of PS for fully homogenous illumination. Luminaire input power: 45 W, Lifetime: 50.000h L80, Chromaticity tolerance (initial MacAdam): 4, Total luminous flux: 5500 lm, Lamp efficacy: 122 lm/W, Colour rendering Ra > 80, colour temperature 4000K. Direct/indirect ratio: 70:30. Tool-free installation (piano key terminal for up to 2.5 mm² wires). Flicker free. Sensor, emergency light conversion, continuous row connector available as accessory. TRIDONIC premium driver (28000656) offering dimming range 1 to 100% via DALI-2, DSI and switchDIM. DC level adjustable. Mains frequency 0/50/60 Hz. Including CorridorFUNCTION. Suitable for emergency escape lighting systems acc. to EN 50172. Suspension kit included. Dimensions: 1200 x 306 x 47 mm
Weight: 3.5 kg.

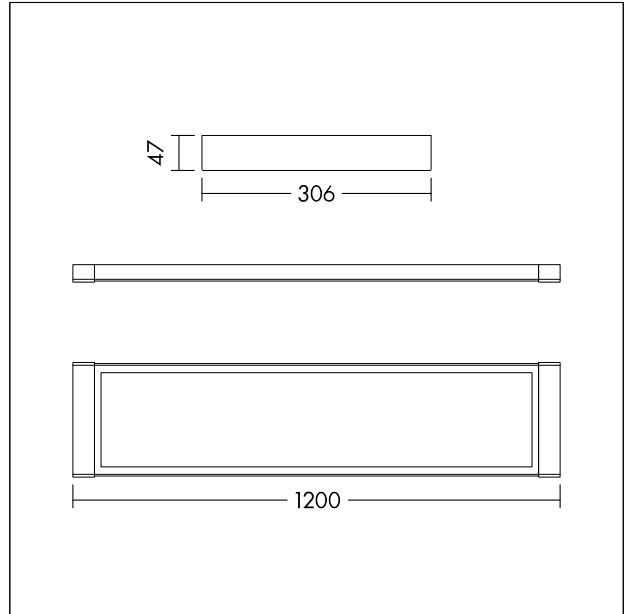

TE_ROXY_F_1200_PEND_Persp.jpg



TE_ROXY_M_1200.wmf

Light Distribution

STD - standard

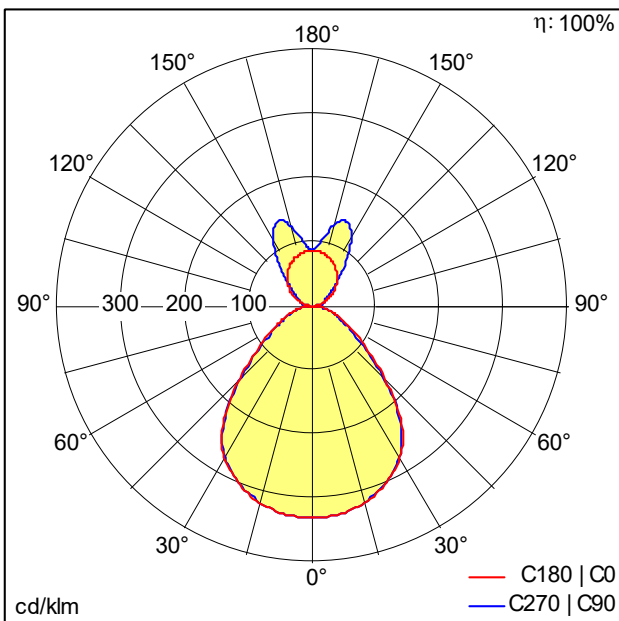

TE_ROXY_1200_DI_5500_840.ltd

- Light Source: LED
- Luminaire luminous flux*: 5489 lm
- Luminaire efficacy*: 122 lm/W
- Colour Rendering Index min.: 80
- Correlated colour temperature*: 4000 Kelvin
- Chromaticity tolerance (initial MacAdam): 4
- Rated median useful life*: L80 50000 h at 25 °C
- Ballast: 1x LED_Con
- Luminaire input power*: 45 W Power factor = 0.95
- Control: HFIX dimmable to 1%
- Maintenance category CIE 97: D - Enclosed IP2X
- Total harmonic distortion (THD): 10.00 %

This product contains light sources of energy efficiency classes D, E.

All values marked with an * are rated values. Connected electrical load and luminous flux are subject to an initial tolerance of +/- 10%, the most similar colour temperature is subject to an initial tolerance of +/- 150K. Unless stated otherwise, the values apply to an ambient temperature of 25°C.